

NANO TALON EVO

User Guide

Thank you for supporting us
buying a Nano Talon EVO

Stay connected with us through our social media channels:



Contact us: info@sonicmodell.com sales@sonicmodell.com
Customer service: cs@sonicmodell.com
www.sonicmodell.com

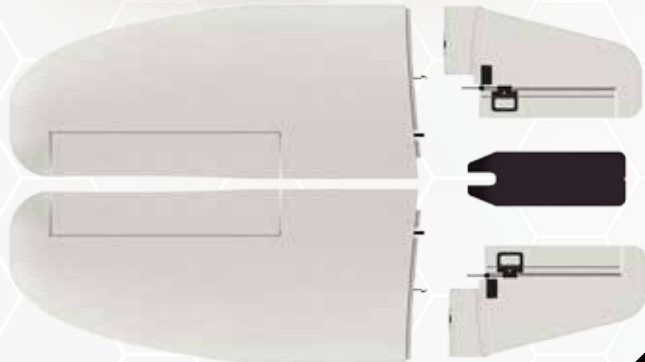

1. After running the main spar through the fuselage,
attach the main wings



2. Install both fins for the V-tail. Be sure the screws that
hold the plastic part of the hinge are looking up

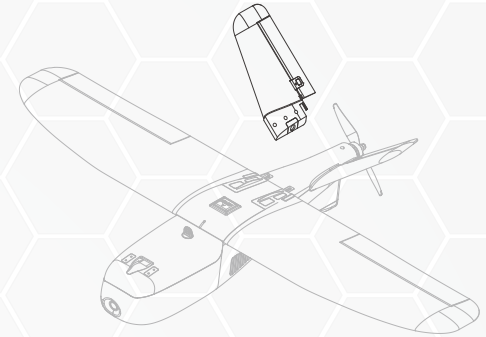

3. Install the middle hatch

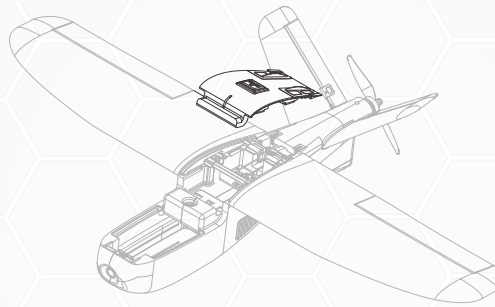

4. Install the battery hatch

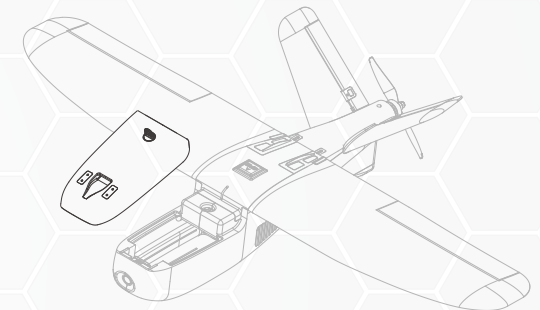

5. Lock the battery hatch twisting the peg

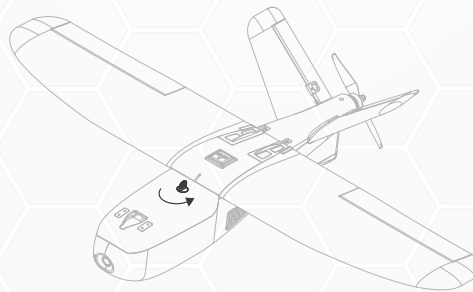

6. Install the bottom hatch

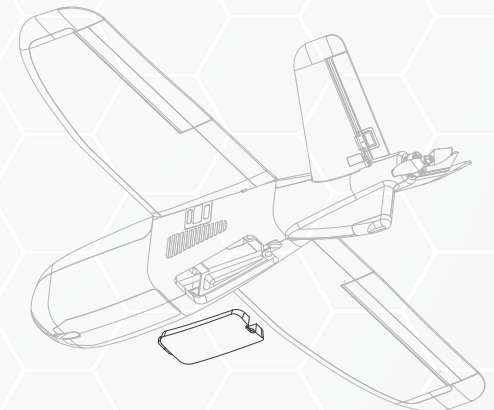

ZOHO
Inspiring The Future

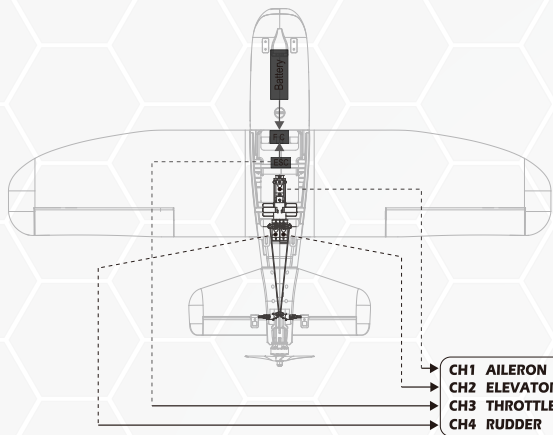

CH1 AILERON
CH2 ELEVATOR
CH3 THROTTLE
CH4 RUDDER

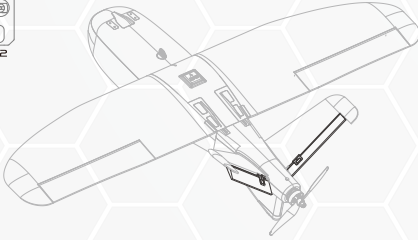
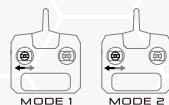
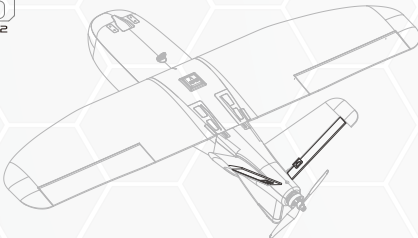
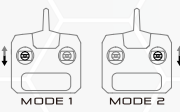
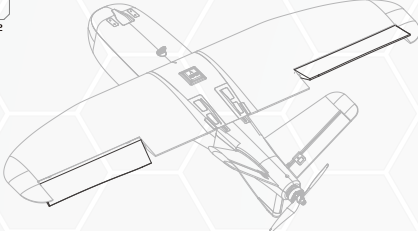
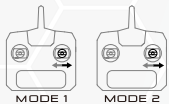

ZOHD

30A ESC

Lite SERIES

01 Specifications

Model	Con. Current (Good heat dissipation)	Burst Current (Good heat dissipation)	BEC	LiPo	Weight (For reference)	Size (For reference)
ZOHD Lite 30A	30A	40A	S:5V / 2A	2-4S	12g	39x15.5x6.5mm

02 Operation instruction

1. Normal start-up

Turn on the transmitter, move the throttle stick to the bottom position.

Connect ESC with battery, wait for 2 seconds, motor emits short "BEEP-" few times, sound times is Lipo battery cells.

Wait for 1 second, it means "No Brake" when motor emit continuously 1 long and 1 short tone. It means "Brake is available" when motor emits a long tone. ESC is ready for working now.

ESC is ready for working now

2. Throttle Range calibration

Turn on the transmitter, move the throttle stick to the top position.

Connect ESC with battery, Wait for 2 seconds, after motor emits 2 short "BEEP-BEEP", the full throttle position is memorized.

Move the throttle stick to the bottom position in 3 seconds. Then waits for 1 second, the "zero throttle position is memorized. Motor emits short "BEEP-" few times, sound times is Lipo battery cells.

Wait for 1 second, it means "No Brake" when motor emit continuously 1 long and 1 short tone. It means "Brake is available" when motor emits a long tone. ESC is ready for working now.

3. Programming

Turn on the transmitter, move the throttle stick to the top position.

Connect ESC with battery, Wait for 2 seconds, motor emits 2 short "BEEP-BEEP". Then still wait for 5 seconds, motor emits special tone "12321", it has entered programming mode.

When motor emits "Exit" tone, move throttle to the zero position in 3 seconds, then motor emits special tone ">765765", it will exit the programming mode.

Select Items
After entering programming mode, you will hear groups tone which emits in a loop as following sequence .

	1	2	3	4	5	6	7	8
1.Brake	1short	1short	Beep-					
2.Battery type	2short	2short	Beep-Beep-					
3.Cutoff voltage	3short	3short	Beep-Beep-Beep-					
4.Timing	4short	4short	Beep-Beep-Beep-Beep-					
5.Startup mode	1long	1long	Beep--					
6.PWM frequency	1long&1short	1long&1short	Beep--Beep					
7.Voltage cutoff option	1long&2short	1long&2short	Beep--Beep-Beep					
8.Battery cells	1long&3short	1long&3short	Beep--Beep-Beep-Beep					
9.Restore factory default	1long&4short	1long&4short	Beep--Beep-Beep-Beep-Beep					
10.Exit	2long	2long	Beep--Beep--					

Note: Usually, 1 long tone "Beep--" equals to 5 short tone "beep-", for example: 1 long tone "Beep--" and 1 short tone "beep-" equals to 6.

Item parameter

After motor emits a item tone, move the throttle to the zero throttle position, then will enter this item, and motor will emits the parameter tone in a loop, please see the table below)

Move throttle stick to the top position after a certain tone that the parameter you want, the parameter is selected, then motor emits special tone "1212", this parameter will be stored. Just wait if you still want select other item, it will go back to the Level 1 menu to select item, the operate method is the same.

If don't want select other parameter, move throttle to the zero position in 3 seconds, then motor emits special tone ">765765", it will exit the programming mode.

Prompt tone	1	2	3	4	5	6	7	8
Item	1short	2short	3short	4short	1long	1long&1short	1long&2short	1long&3short
1.Brake	NO	Soft	Heavy	Very Heavy				
2.Battery type	LiPo	NiCb/NiMh						
3.Cutoff voltage	2.8V	3.0V	3.2V					
4.Timing	0°	3.75°	7.5°	11.25°	15°	18.75°	22.5°	26.25°
5.Startup mode	Normal	Soft	Very Soft					
6.PWM frequency	12KHz	8KHz						
7.Voltage cutoff option	Reduce cutoff	Cut off						
8.Battery cells	Auto	2S	3S	4S				

*Shadow parts are factory default value

1.Brake: [1]NO(default) [2]Soft [3]Heavy [4]Very heavy

2. Battery type: [1] LiPo(default) [2] NiCb/NiMh

3. Cutoff voltage: Low-voltage protection threshold, [1] Low [2] Medium (default) [3]High, For Ni-xx battery packs: Low/Medium/High cut off voltage is 50%/65%/75% of the battery packs initial voltage, For LiPo battery: can count battery cells automatic. Low voltage protection threshold :Low (2.8V) /Medium (3.0V) /High(3.2V). Eg:For 4S/14.8V Lipo battery packs, low voltage protection threshold is 11.2V low/12.0V medium /12.8V high

4. Timing:
[1]0" [2]3.75" [3]7.5" [4]11.25" [5]15 (default) [6]18.75 [7]22.5" [8]26.25
Low (013.759/ 11.259/15 / 18.759)—for most inner rotor motors hail(22.5/26.25)—For 6 poles or higher poles outer rotor motors as usual 15 applies to all the outer rotor motors, but for improving efficiency recommend that set low timing for 2 poles motor(most inner rotor motors), set high timing for 6 poles and high poles motors(most outer rotor motors). If not sure, you'd better to set timing as motor manufacturer recommended ,or set 150.Note: After changing timing, please test on the ground before flying

5. Startup Mode: Start up with linear acceleraton

[1] Normal: No latency from 0% throttle to 100% throttle. (default)

[2] Soft: It takes 6 seconds from 0% throttle to 100% throttle.

[3] Very soft: It takes 12 seconds from 0% throttle to 100% throttle.

6. PWM frequency: [1]12KHz (default) [2]8KHz
For high poles and high speed motors, the higher PWM frequency can make motor drive smoothly, but the higher PWM frequency will make ESC hotter.

7. Voltage cutoff option:
[1] Reduce cutoff(default): the voltage drops to the set low-voltage protection threshold. ESC will reduce the power then cut off the motor output
[2] Cut off: the voltage drops to the set low-voltage protection threshold, ESC will cut off the motor output immediately.

8.Battery cells: Available for Lipo battery only.
[1] Automatic judgment(default) [2]2S [3]3S [4]4S
You also can select the options according to your battery cells.

9.Restore default settings
When the beeping indicates the mode of "Restore default settings", move the throttle stick to zero position in 5 seconds after the beeping can activate the mode. There is no sub-menu under this mode, the motor makes indication tones of "12321" which means default settings are restored. At this time if moving the throttle stick to top position.ESC will enter programming mode again, if keeping the hrottle stick to bottom position.ESC will enter the first programming item(Brake).

10.Exit program mode
After a sound "Beep-" , move throttle stick to the bottom position, enters the item of exit program mode, motor emits sound "765765" the same time, it represents ESC enters normal operation mode.